



D50

SITE DUMPER



ENGINE	TIER 4 FINAL EPA
Model:	KOHLER series KDI 1903 TCR
Type:	Turbo Intercooler
Displacement, No. cylinders:	1,861cc - 3 inline
Injection:	Electronic Control w/ Common Rail
Aftertreatment system:	EGR + DOC
Cooling:	Air Water, Dry Air Filter
Maximum Power:	56 hp (42 kW)
Adj. Power:	56 hp (42 kW) @ 2,600 rpm
Maximum Torque:	166 lbf.ft (225 Nm) @ 1,500 rpm
Alternator:	12 V - 55 A

4 X 4 DRIVE

Hydrostatic "automotive" transmission with variable displacement pump and variable displacement hydraulic motor with electro-hydraulic control, and reverse gear control on the steering wheel.

Speed:

	forward gears,	reverse gears
Slow	0 - 4.4 mph	0 - 4.4 mph
Fast	0 - 13.0 mph	0 - 13.0 mph

Traction / weight ratio: 41%

AXLES AND WHEELS

Front load-bearing, oscillating ($\pm 6.5^\circ$) with planetary reduction gears on the wheel hubs.

Rear load-bearing with planetary reduction gears on the wheel hubs.

Standard Tires: 12.5 - 18 16PR

Turf Tires: 12.5/80 - 18 16PR

ELECTRIC SYSTEM

Battery:

Tier 4F 12 V - 80 Ah

LED road light system, rear working lights.

EQUIPMENT HYDRAULIC SYSTEM

Gear Pump:

Max. low rate: 9.51 gal/min

Max. pressure: 200 bar

2 - elements distributor.

Aluminium heat exchanger for hydraulic oil cooling.

Pressurized closed-circuit intake with oil filter replaceable from the outside.

CAB

Open cab designed according to ROPS & FOPS Level II criteria, windows on three sides.

Sliding window on cabin door. AC standard.

180° pivoting driving post. Anatomic seat with flexible suspension and height adjustment, seat belts.

Driving and equipment controls with ergonomic arrangement.

LCD display with reverse camera.

STEERING

Assisted by means of power steering acting on 2 half-frames by means of two opposed jacks.

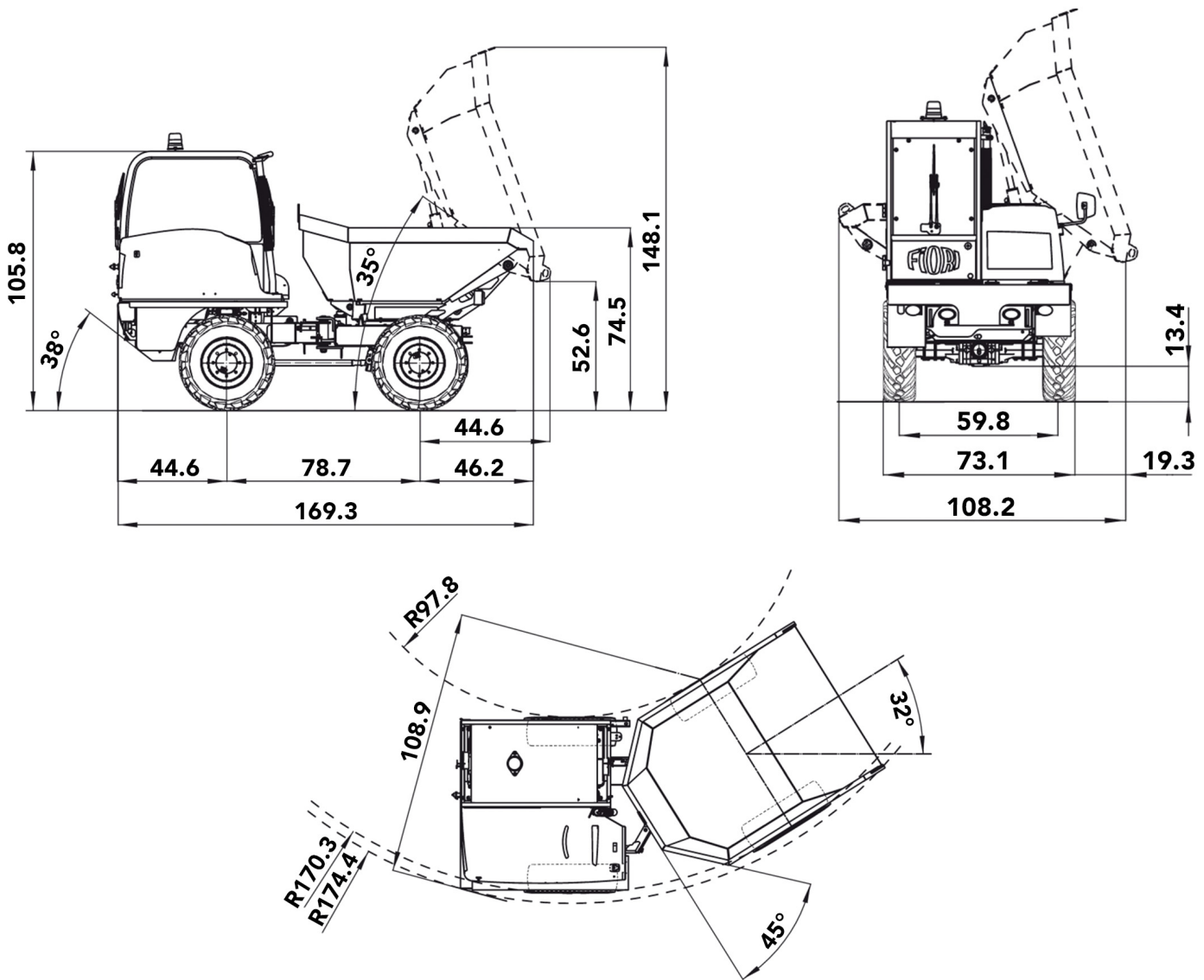

DUMP BODY

Dump body tilting by means of 1 double-acting jack. Orientation over 180° for trilateral unloading by means of two opposing jacks.

Struck capacity: 2.88 cu yd
 SAE heaped capacity: 3.6 cu yd

WEIGHTS

Operating weight: 8,600 lb
 Max. gross weight: 19,620 lb
 Load-carrying capacity: 11,023 lb

BRAKES

Internal oil-bath disc service and emergency brakes acting on the 4 wheels, activation with pump on independent dual circuit.

Negative-type parking brake with internal oil-bath discs on the rear axle and electro-hydraulically controlled release.

SERVICE REFILL CAPACITIES

Fuel tank: 13.2 gal
 Total hydraulic system capacity: 19.6 gal
 Engine oil: 15.43 lb